

Wire 3/4 circle carousels kit

Kit girelli 3/4 Wire

Meccanismi angolari | Corner mechanisms

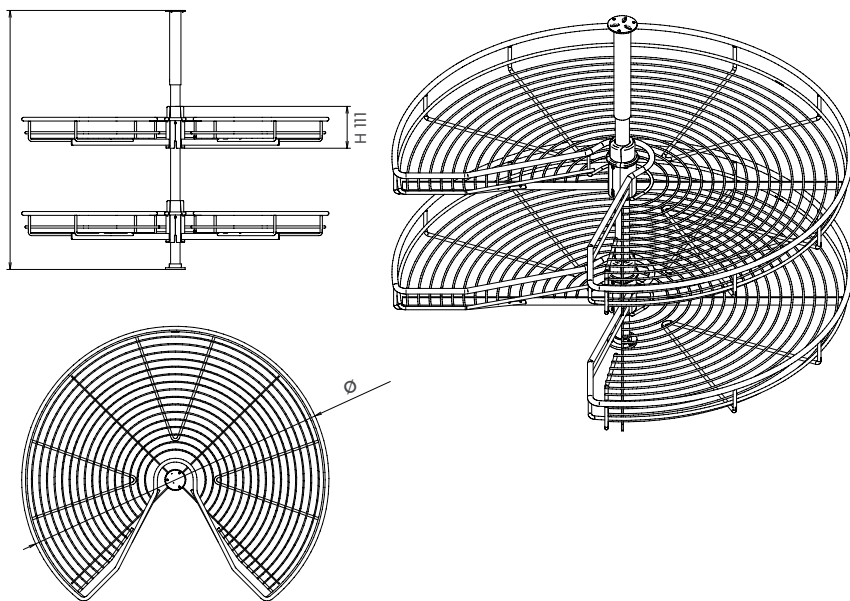

Cat. code

CG734TFBM2

CG	Nome Name
734	Misura Size
T	Tubo Tube
FB	Sistema di aggancio "Fast block"
	"Fast block" fittings
M2	Ripiani Tiers

Instruction sheet

4004109400MKT

Finish

C
Cromo
Chrome-plated

Materials

Metallo Metal
Plastica Plastic

Load capacity Kg



Portata totale 734
Total capacity 734



Portata totale 834
Total capacity 834

Description

Kit composto da 2 girelli 3/4 con sistema di aggancio "fast-block", completo di staffa di trascinamento e tubo cromato.

Kit consisting of 2 3/4 circle carousels with "fast block" fittings, equipped with sliding bracket and chrome-plated tube.

Dimensions

Cat. code	Diameter (mm)	Depth (mm)	Height (mm)
CG734TFBM2	715	—	111
CG834TFBM2	815	—	111

Packaging

Cat. code	Size (cm)	Weight (kg)	Size (mm)	Pieces
CG734TFBM2			1200 x 800	14
CG834TFBM2			1200 x 800	14

Pallet configuration

Maintenance

Inquadrate il codice QR per scoprire il modo corretto di smaltire l'imballaggio e la corretta manutenzione del prodotto.

Scan the QR code to discover the correct way to dispose the packing and the correct maintenance of the product.

