

MoveBin with automatic lids

MoveBin automatico

Sistemi per la raccolta differenziata | Waste recycling bin systems

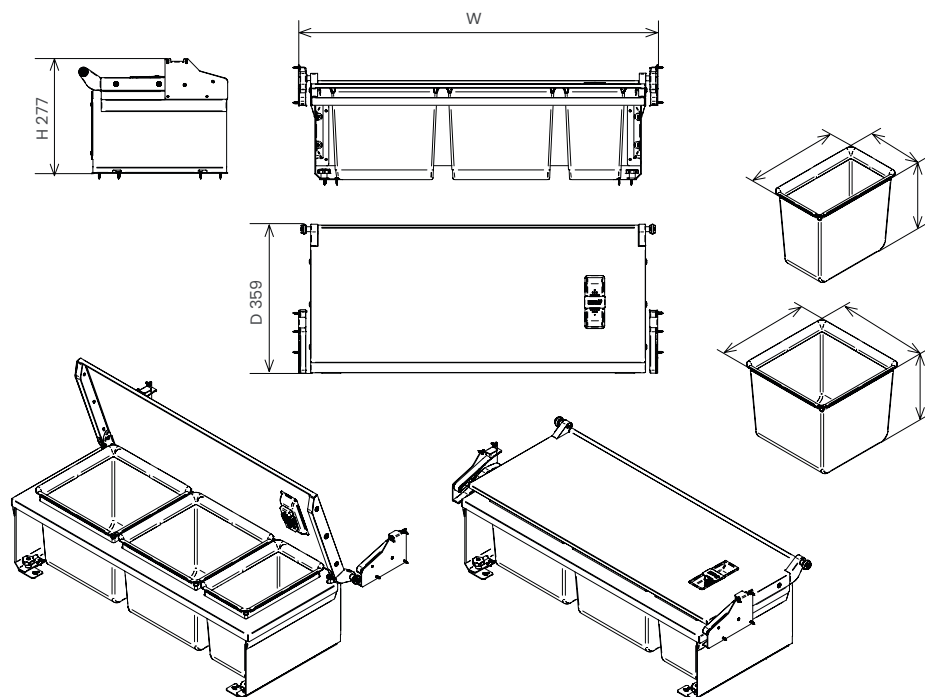

Cat. code

MVB090A

MVB Nome Name
90 Modulo Cabinet size
A Automatico Automatic

Instruction sheet

4004110318MKT

Finish

GM
Grigio Materico

Materials

Lamiera Sheet metal
Plastica Plastic

Capacity Lt



Description

Kit per sottolavello inferiore con coperchio automatico composto da un basamento in lamiera elettrozincata e verniciata a doppio trattamento da appoggiare sul fondo del cassetto con fori prespaziati dove poter alloggiare i nuovi contenitori in plastica dotati di collarini. Il coperchio è compreso di sezione dedicata all'umido con filtro a carboni attivi, anti-odore e lavabile di serie.

Kit for lowersink unit with an automatic lid consisting of an electro-galvanized sheet metal base, which has been epoxy-coated with a double treatment. Designed to be placed on the bottom of the drawer with pre-spaced holes that can accommodate the new plastic containers with collars. The lid includes a wet section with an anti-smell, washable, activated carbon filter as standard.

Dimensions

Cat. code	Capacity (Lt)	Width (mm)	Depth (mm)	Height (mm)
MVB060A	16,5 + 10 L	503-519	359	277
MVB075A	16,5 + 16,5 L	653-669	359	277
MVB080A	16,5 + 10 + 10 L	703-719	359	277
MVB090A	16,5 + 16,5 + 10 L	803-819	359	277
MVB0120A	16,5 + 16,5 + 16,5 + 10 L	1103-1119	359	277

Packaging

Cat. code	Size (cm)	Weight (kg)	Size (mm)	Pieces
MVB060A	27,8 x 40,2 x 71,1	ND*	1200 x 800	21
MVB075A	27,8 x 40,2 x 71,1	ND*	1200 x 800	21
MVB080A	27,8 x 40,2 x 71,1	ND*	1200 x 800	14
MVB090A	27,8 x 40,2 x 86,1	ND*	1200 x 800	14
MVB0120A	27,8 x 40,2 x 116,1	ND*	1200 x 800	14

Pallet configuration

Maintenance

Inquadrate il codice QR per scoprire il modo corretto di smaltire l'imballaggio e la corretta manutenzione del prodotto.

Scan the QR code to discover the correct way to dispose the packing and the correct maintenance of the product.



*Non disponibile al momento Not available at the moment



Vibo S.p.A Via Arzignano, 46 36070
Trissino VI - Italy | Tel +39 0445 492800
vibo@viboitaly.com | viboitaly.com

*Le informazioni contenute nelle presenti schede tecniche sono indicative. Eventuali differenze con il listino in vigore non costituiscono motivo di contestazione. The information given in this technical sheet are indicative. Any discrepancies with the price list currently in force cannot be cause for complaint.