

Elite 3-tier side-mounted shoe rack

Scarpiera laterale a 3 ripiani Elite

Scarpiera | Shoe racks

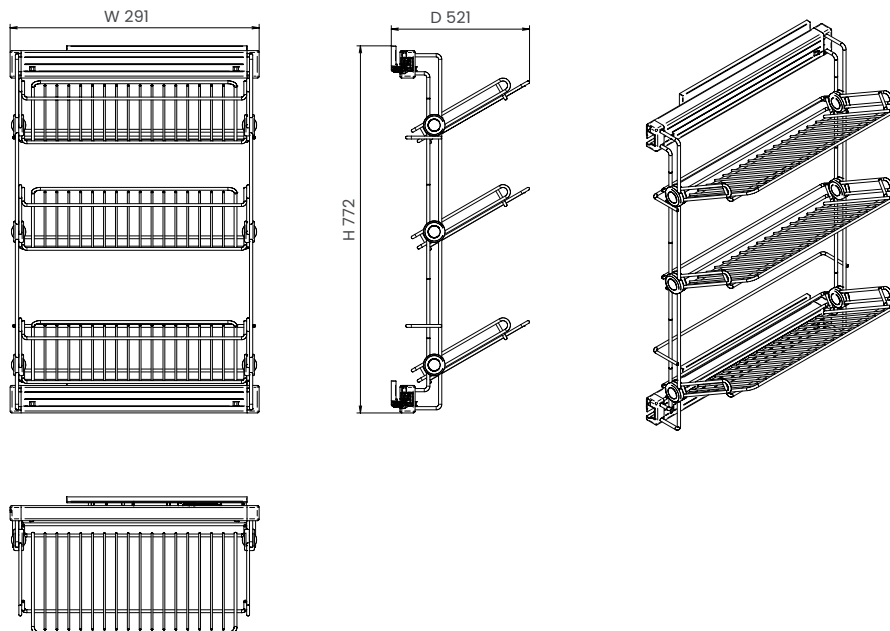

Cat. code

ASL3SMDX

ASL Nome Name

3 Ripiani Tiers

SM

DX Orientamento Direction

Instruction sheet

4004115330MKT

Finish

ALVG

Grigio Alluminio

Aluminium grey

Materials

Metallo Metal

Plastica Plastic

Description

Scarpiera laterale a 3 ripiani in filo. Disponibile in versione destra e sinistra e completo di guide ad estrazione totale con rientro ammortizzato. Ferramenta per il fissaggio al fianco del mobile inclusa.

3-tier side-mounted wire shoe rack. Right and left versions are available and equipped with total extension slides and dampened soft-closing system. Fittings for cabinet's side fastening are included.

Load capacity Kg



Portata totale
Total capacity

Maintenance

Inquadrate il codice QR per scoprire il modo corretto di smaltire l'imballaggio e la corretta manutenzione del prodotto.

Scan the QR code to discover the correct way to dispose the packing and the correct maintenance of the product.



Dimensions

Cat. code	Cabinet size (cm)	Width (mm)	Depth (mm)	Height (mm)
ASL3SMDX	—	291	521	772
ASL3SMSX	—	291	521	772

Packaging

Cat. code	Size (cm)	Weight (kg)	Size (mm)	Pieces
ASL3SMDX			1200 x 800	ND*
ASL3SMSX			1200 x 800	ND*

Pallet configuration

*Non disponibile al momento Not available at the moment