

Ambrogio Elite

Ambrogio Elite

Appendiabiti | Clothes hangers

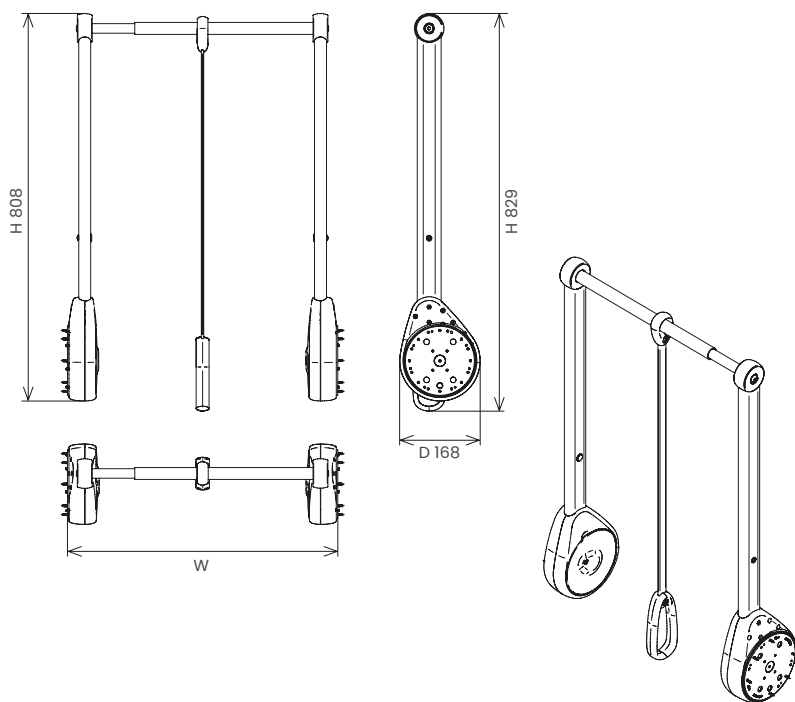

Cat. code

ASSA50/75

ASSA 50/75 Nome Name
Misura Dimension

Instruction sheet

4004117470MKT

Finish

VG

Verniciato grigio
Light grey

Materials

Metallo Metal
Plastica Plastic

Load capacity Kg



Portata totale
Total capacity

Description

Appendiabiti saliscendi predisposto per il fissaggio al fianco del mobile. Regolabile in larghezza e completo di ammortizzatori che intervengono sia nella fase di discesa che di salita. Parti plastiche con trattamento opacizzante. Portata 12 kg.

Width-adjustable wardrobe lift with dampened soft-closing system both in the descent and ascent phases. Designed for cabinet's side fastening. Plastic components with matt finishing. Load capacity 12 kg.

Dimensions

Cat. code	Cabinet size (cm)	Width (mm)	Depth (mm)	Height (mm)
ASSA50/75	—	500-750	168	808
ASSA75/125	—	750-1250	168	808

Packaging

Cat. code	Size (cm)	Weight (kg)	Size (mm)	Pieces
ASSA50/75	82,5 x 25,5 x 11	7,0	1200 x 800	68
ASSA75/125	82,5 x 25,5 x 11	7,5	1200 x 800	68

Pallet configuration

Maintenance

Inquadrate il codice QR per scoprire il modo corretto di smaltire l'imballaggio e la corretta manutenzione del prodotto.

Scan the QR code to discover the correct way to dispose the packing and the correct maintenance of the product.

